



Kangaroo 2018 Student

Upper Secondary (lukio)



NAME _____

CLASS _____

Points: _____

Kangaroo leap: _____

Separate this answer sheet from the test. Write your answer under each problem number.

A right answer gives 3, 4 or 5 points. Every problem has exactly one right answer.

For each wrong answer, $\frac{1}{4}$ of the points of the problem will be deducted, for example for a 4-point problem -1 point. If you leave the answer empty, no deduction will be made.

There are two goals: to score as many points as possible or to have as many consecutive right answers as possible (Kangaroo leap).

3 points

PROBLEM	1	2	3	4	5	6	7	8	9	10
ANSWER										

4 points

PROBLEM	11	12	13	14	15	16	17	18	19	20
ANSWER										

5 points

PROBLEM	21	22	23	24	25	26	27	28	29	30
ANSWER										

Contest not to be held before 15th of March.

Logo design by Veijo Nurminen.





Kangaroo 2018 Student Upper Secondary (lukio)

3 points

1.

In the figure you see a calendar of a certain month. Unfortunately, some ink fell on it. Which day of the week was the 27th of that month?

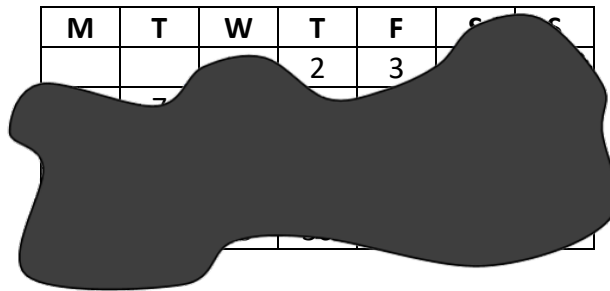

- (A) Monday (B) Wednesday (C) Thursday (D) Saturday (E) Sunday

2.

Which of the following expressions has the highest value?

- (A) $2 - 0 \cdot 1 + 8$ (B) $2 + 0 \cdot 1 \cdot 8$ (C) $2 \cdot 0 + 1 \cdot 8$ (D) $2 \cdot (0 + 1 + 8)$ (E) $2 \cdot 0 + 1 + 8$

3.

A little Kangaroo has stacked the discs of his toy as seen in the figure. How many of the discs are can be seen from above?

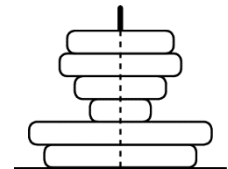

- (A) 1 (B) 2 (C) 3 (D) 4 (E) 5

4.

The figure shows the floor plan of Marie's house. Marie enters from the porch and walks through each door exactly once. In which room does she end up?

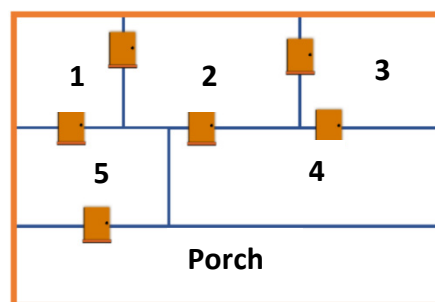

- (A) 1 (B) 2 (C) 3 (D) 4 (E) 5



Kangaroo 2018 Student Upper Secondary (lukio)

5.

Thor has seven stones and a hammer. Every time he hits a stone with his hammer the stone breaks into exactly five smaller stones. Which of the following numbers could be the number of stones he ends up with?

- (A) 17 (B) 20 (C) 21 (D) 23 (E) 25

6.

The shape shown is made of 10 cubes glued together. The entire shape is dipped into a bucket of paint. How many of the cubes will be painted on exactly four of their faces?

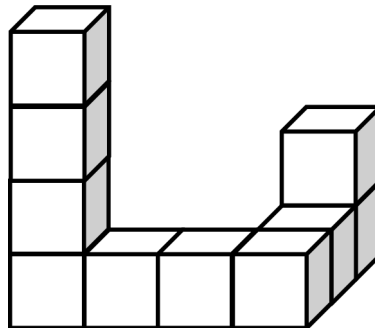

- (A) 6 (B) 7 (C) 8 (D) 9 (E) 10

7.

Kalle cut a string into three equally long pieces. Then he tied some identical knots to them. Which of the figures below could show the strings Kalle cut?

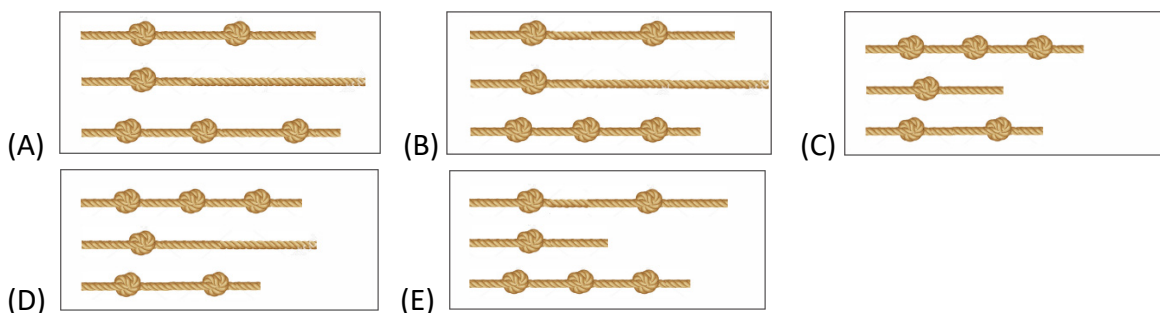

8.

In my family every child has at least two brothers and at least one sister. At least how many children are there in my family?

- (A) 3 (B) 4 (C) 5 (D) 6 (E) 7



Kangaroo 2018 Student
Upper Secondary (lukio)

9.

Three identical regular hexagons A , B and C are partially shaded, so that the shaded parts of each hexagon have areas X , Y and Z respectively. Which of the following statements is true?

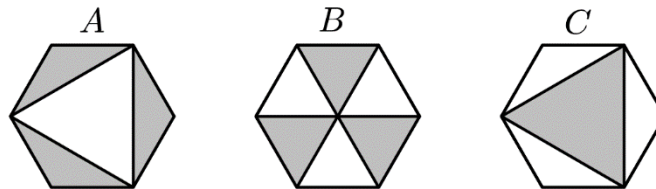

- (A) $X = Y = Z$ (B) $Y = Z \neq X$ (C) $Z = X \neq Y$ (D) $X = Y \neq Z$ (E) X, Y and Z are all different.

10.

Four balls weigh 10 kg, 20 kg, 30 kg and 40 kg. Which ball weighs 30 kg?

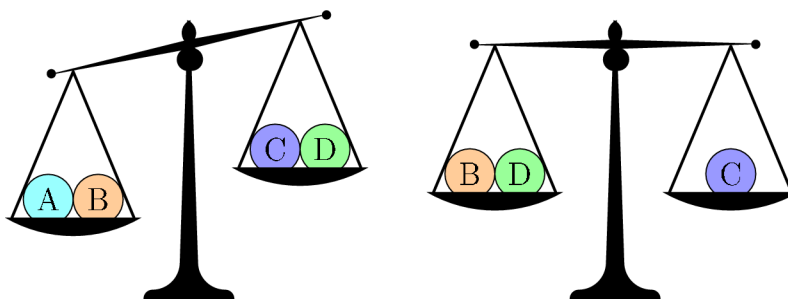

- (A) A (B) B (C) C (D) D (E) A or B

4 points

11.

The following two statements are true: Some aliens are green, and the others are purple. Green aliens only live on Mars. Therefore, it is certain that

- (A) All aliens live on Mars.
(B) Only Green aliens live on Mars.
(C) Some purple aliens live on Venus.
(D) All the purple aliens live on Venus.
(E) None of the green aliens live on Venus.



12.

The volumes of two cubes are V and W . The cubes are partially inside each other. Of the volume V , 90 % is outside the common part of the cubes. Of the volume W , 85 % is outside the common part. Which of the following is true?

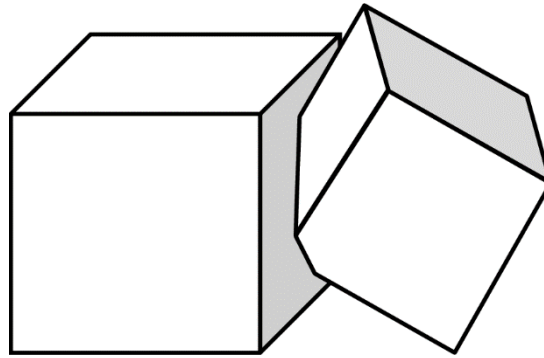

- (A) $V = \frac{2}{3}W$ (B) $V = \frac{3}{2}W$ (C) $V = \frac{85}{90}W$ (D) $V = \frac{90}{85}W$ (E) $V = W$

13.

Four identical rhombuses and two squares are put together to make a regular octagon. What is the measure of the larger angle of each rhombus?

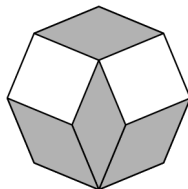

- (A) 135° (B) 140° (C) 144° (D) 145° (E) 150°

14.

A vase is filled up to the top with water, at a constant rate. The graph shows the height h of the water as a function of time t .

Which of the following could be the shape of the vase?

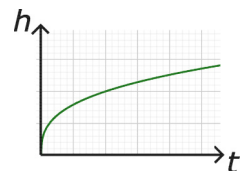

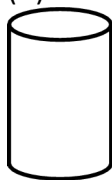
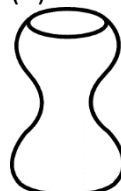
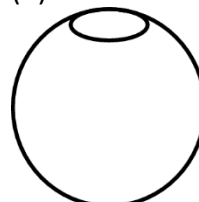
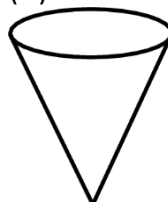
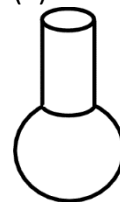
- (A)  (B)  (C)  (D)  (E) 



Kangaroo 2018 Student
Upper Secondary (lukio)

15.

Two vertices are inclined to the vertical line at angles 40° and 30° as shown. What is the measure of the angle θ ?

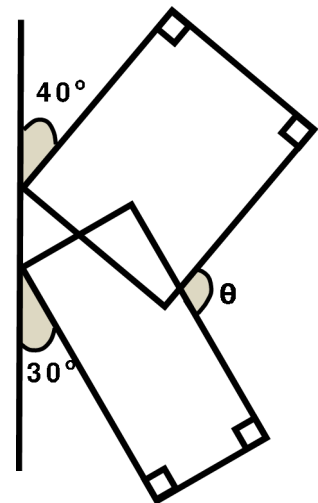

- (A) 105° (B) 120° (C) 130° (D) 135° (E) some other

16.

Two buildings are located on a street 250 metres from each other. There are 100 students living in the low building, and there are 150 students living in the high building. They all use the bus daily. Where should the bus stop be built, so that the total walking distance to the bus stop of all the students would be the shortest possible?

- (A) In front of the low building.
(B) 100 meters from the low building.
(C) 100 meters from the high building.
(D) In front of the high building.
(E) Anywhere between the buildings.

17.

The faces of a rectangular brick have areas A , B and C as shown. What is the volume of the brick?

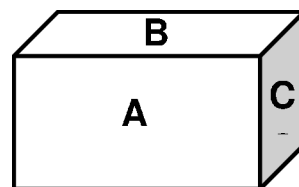

- (A) ABC (B) \sqrt{ABC} (C) $\sqrt{AB + BC + CA}$ (D) $\sqrt[3]{ABC}$ (E) $2(A + B + C)$



Kangaroo 2018 Student
Upper Secondary (lukio)

18.

A clock is hung from its minute arm, so that the clock rotates as it operates normally. Harri stares at the clock intensively for 24 hours. How many full circles does he see the hour arm make?

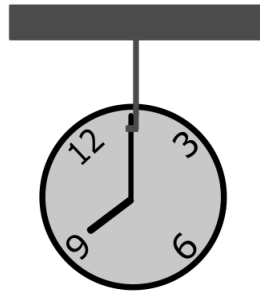

(A) 22

(B) 23

(C) 24

(D) 25

(E) 26

19.

$$|\sqrt{17} - 5| + |\sqrt{17} + 5| =$$

(A) 10

(B) $2\sqrt{17}$

(C) $\sqrt{34} - 10$

(D) $10 - \sqrt{34}$

(E) 0

20.

A triangle has vertices $A(p, q)$, $B(r, s)$ and $C(t, u)$ as shown in the figure. The midpoints of its sides are $M(-2, 1)$, $N(2, -1)$ and $P(3, 2)$. What is the value of the sum $p + q + r + s + t + u$?

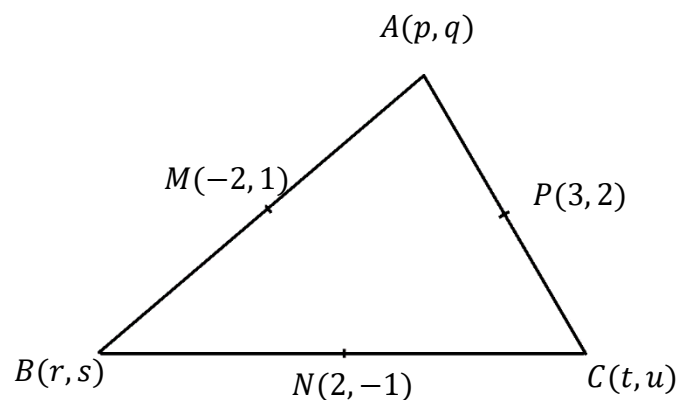

(A) 2

(B) $\frac{5}{2}$

(C) 3

(D) 5

(E) none of the previous



5 points

21.

Five predictions were made before the football match Real Madrid - Manchester United:

1. The game will not end in a draw.
2. Real Madrid will score.
3. Real Madrid will win.
4. Real Madrid will not lose.
5. Three goals will be scored in the match.

After the game it turned out that exactly three of the predictions came true. What was the final score?

- (A) 3 - 0 (B) 2 - 1 (C) 0 - 3 (D) 1 - 2 (E) This situation is not possible.

22.

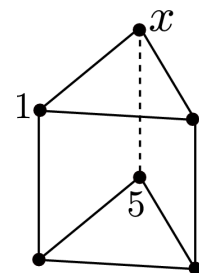
The prism in the picture is formed of two triangles and three squares. The six vertices are numbered from 1 to 6 in such a way that the sum of the four vertices of each square is the same for all three squares. Numbers 1 and 5 are already shown. What number is at the vertex labelled x ?

- (A) 2 (B) 3 (C) 4 (D) 5 (E) The situation is impossible.

23.

Which of these five numbers does **not** divide $18^{2018} + 18^{2017}$?

- (A) 8 (B) 18 (C) 28 (D) 38 (E) 48

24.

An octahedron is inscribed in a cube of side length 1. The vertices of the octahedron are at the centers of the faces of the cube.

What is the volume of the octahedron?

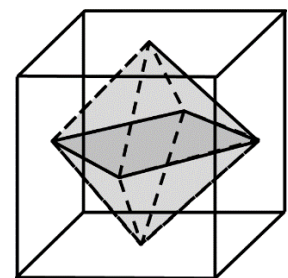

- (A) $\frac{1}{3}$ (B) $\frac{1}{4}$ (C) $\frac{1}{5}$ (D) $\frac{1}{6}$ (E) $\frac{1}{8}$

**25.**

Kanga-Burger issues rather strange discount coupons! The coupons can be combined in any order. You have the following coupons:

1. Any product for the square root of the price!
2. Discount: 2 €.
3. Pay 1 € more for any product!
4. 50 % off any integer price!

What is the least you can pay for a 15 € DeLuxe-burger?

- (A) under 2 €, but over 1 € (B) 1 € (C) under 1 €, but over 0 € (D) I can get it for free. (E) The shop pays me.

26.

A regular pentagon is cut of a lined piece of paper. In each step we rotate the pentagon counterclockwise around its centre by 21° . The situation after the first step is shown.

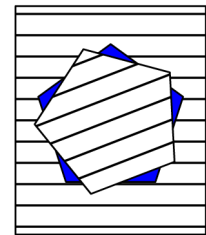

What will we see when the pentagon first fits in the hole?

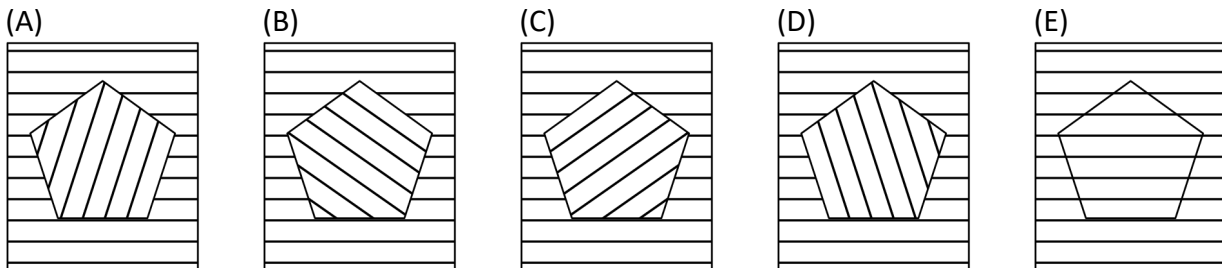
**27.**

How many real solutions does the equation $||4^x - 3| - 2| = 1$ have?

- (A) 2 (B) 3 (C) 4 (D) 5 (E) 6

28.

Let f be a function that satisfies $f(x + y) = f(x) \cdot f(y)$ for all integers x and y . It is known that $f(1) = \frac{1}{2}$. What is the value of the sum $(0) + f(1) + f(2) + f(3)$?

- (A) $\frac{1}{8}$ (B) $\frac{3}{2}$ (C) $\frac{5}{2}$ (D) $\frac{15}{8}$ (E) 6



Kangaroo 2018 Student
Upper Secondary (lukio)

29.

The graph of the function $P(x) = x^2 + px + q$ intercepts the x - and the y -axis in three different points. A circle is drawn through these points. The circle intercepts the graph of P in a fourth point as well. What are its coordinates?



- (A) $(0, -q)$ (B) (p, q) (C) $(-p, q)$ (D) $\left(-\frac{q}{p}, \frac{q^2}{p}\right)$ (E) $(1, p + q)$

30.

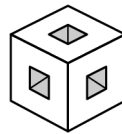
Seven small $1 \times 1 \times 1$ -cubes have been removed from a $3 \times 3 \times 3$ cube so that there are three square-shaped holes through the cube.

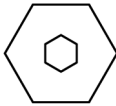

Then the large cube is cut by a plane passing through the centre of the cube and perpendicular to one of its big diagonals. What will the cross-section look like?

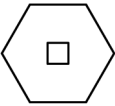
- (A)  (B)  (C)  (D)  (E) 