

3 point questions:

1. Mike is building a race track.

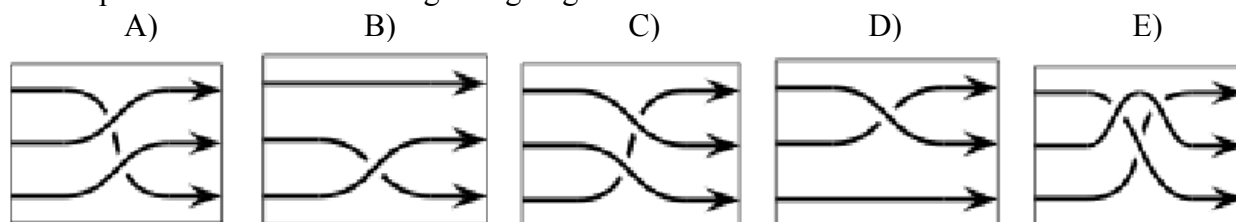

He noticed that the order of cars is not the same as in the beginning. Which element should Mike take to replace element X at the beginning to get the correct order of cars at the end?



2. Three boys have 30 balls together. If Ben gives 5 to Chen, Chen gives 4 to Anh and Anh gives 2 to Ben, then the boys will each have the same number of balls. How many balls does Anh have at the beginning?

- A) 8 B) 9 C) 11 D) 12 E) 13

3. O is the centre of the circle. The shaded area is equal to $\sqrt{3}$. What is the area of the triangle ABC?

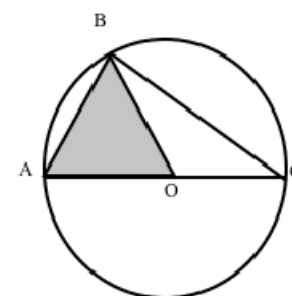

- A) $2\sqrt{3}$ B) 2 C) 5 D) 4 E) $4\sqrt{3}$

4. $\frac{\sin 1^\circ}{\cos 89^\circ}$ equals

- A) 0 B) $\tan 1^\circ$ C) $\tan\left(\frac{1}{89}\right)^\circ$ D) $\frac{1}{89}$ E) 1



5. The billiard ball meets the board under 45° as shown. Which pocket will it fall into?

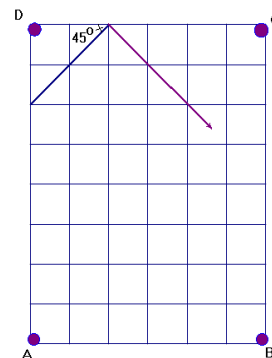

- A) A B) B C) C D) D E) neither of the pockets

6. Some historians claim that the ancient Egyptians used a string with 2 knots to construct a right angle. If the length of the string is 12 m and one of the knots is at the point X, 3 m far from one end, at what distance from the other end of the string should the second knot be put in order to obtain a right angle at X?

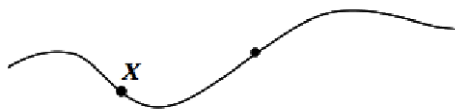

- A) 3m B) 4m C) 5m D) 6m E) another answer

7. At the entrance examination to a university, a student must answer at least 80% of the questions correctly. So far, Peter has worked on 15 questions. He did not know the answer to 5 of them, but he is sure that he has answered the other 10 questions correctly. If he answers all the remaining questions in the test correctly, he will pass the test at exactly 80%. How many questions are there in the test?

- A) 20 B) 25 C) 30 D) 35 E) 40

8. Which of the following objects can be created by rotating the given object in space?

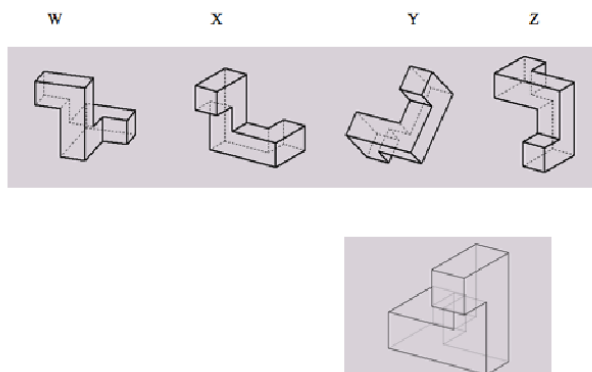

- A) W and Y B) X and Z C) only Y D) none of these E) W, X and Y



9. AE is divided into four equal parts and semicircles are drawn taking AE, AD and DE as diameters, creating paths from A to E as shown. Determine the ratio of the length of the upper path to the length of the lower path.

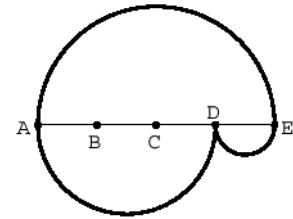

- A) 1 : 2 B) 2 : 3 C) 2 : 1 D) 3 : 2 E) 1 : 1

10. A mathematically skilled spider spins a web and some of the strings have lengths as shown in the picture. If x is an integer, determine the value of x .

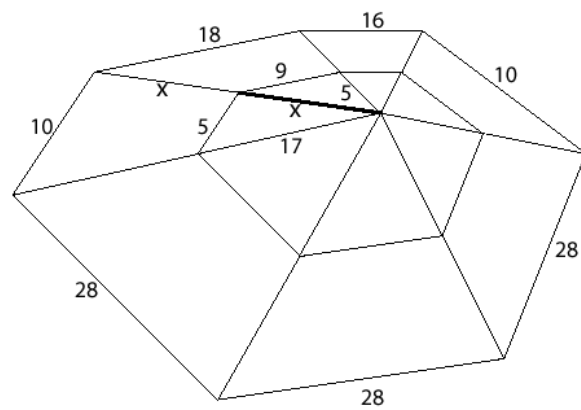

- A) 11 B) 13 C) 15 D) 17 E) 19



4 point questions:

11. Given a square ABCD with side 1, all squares are drawn that share at least two vertices with ABCD. The area of the region of all points covered by at least one of these squares is

- A) 5 B) 6 C) 7 D) 8 E) 9

12. Angle β is 25% less than angle γ and 50% greater than angle α . Angle γ is

- A) 25% greater than α B) 50% greater than α C) 75% greater than α D) 100% greater than α E) 125% greater than α

13. Given $2^{x+1} + 2^x = 3^{y+2} - 3^y$, where x and y are integers, the value of x is

- A) 0 B) 3 C) -1 D) 1 E) 2

14. What is the value of $\cos 1^\circ + \cos 2^\circ + \cos 3^\circ + \dots + \cos 358^\circ + \cos 359^\circ$?

- A) 1 B) π C) 0 D) 10 E) -1

15. Two semicircles are drawn as shown in the figure. The chord CD, of length 4, is parallel to the diameter AB of the greater semicircle and touches the smaller semicircle. Then the area of the shaded region equals

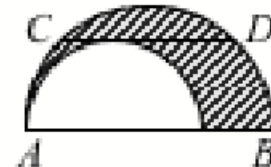

- A) π B) $1,5\pi$ C) 2π D) 3π E) not enough given

16. The sum of five consecutive integers is equal to the sum of the next three consecutive integers. The greatest of these eight numbers is:

- A) 4 B) 8 C) 9 D) 11 E) something else

17. Thomas was born on his mother's 20th birthday, and so they share birthdays. How many times will Thomas' age be a divisor of his mother's age if they both live long lives?

- A) 4 B) 5 C) 6 D) 7 E) 8

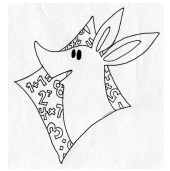

18. An island is inhabited by knights and liars. Each knight always tells the truth and each liar always lies. Once an islander A, when asked about himself and another islander B, claimed that at least one of A and B is a liar. Which of the following sentences is true?

- A) A is not able to make the above statement.
- B) Both are liars.
- C) Both are knights.
- D) A is a liar while B is a knight.
- E) B is a liar while A is a knight.

19. Consider a sphere of radius 3 with centre at the origin of a cartesian coordinate system. How many points on the surface of this sphere have integer coordinates?

- A) 30 B) 24 C) 12 D) 6 E) 3

20. Find the graph of the function $\sqrt{(1+x)(1-|x|)}$.

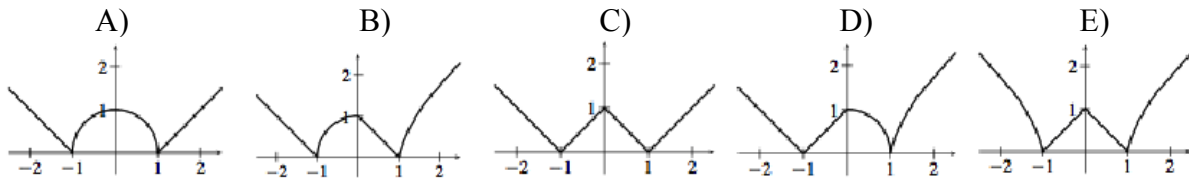



5 point questions:

21. Which of the following numbers can't be written as $x + \sqrt{x}$, if x is an integer?

- A) 870 B) 110 C) 90 D) 60 E) 30

22. If $f(x) = \frac{2x}{3x+4}$ and $f(g(x)) = x$, then $g(x) =$

- A) $\frac{3x+4}{2x}$ B) $\frac{3x}{2x+4}$ C) $\frac{2x+4}{4x}$ D) $\frac{4x}{2-3x}$ E) other answer

23. Ann, Belinda and Charles are throwing a die. Ann wins if she throws a 1, 2 or 3; Belinda wins if she throws a 4 or 5; Charles wins if he throws a 6. The die rotates from Ann to Belinda to Charles to Ann, etc., until one player wins. Calculate the probability that Charles wins.

- A) $\frac{1}{6}$ B) $\frac{1}{8}$ C) $\frac{1}{11}$ D) $\frac{1}{13}$ E) It is impossible for Charles to win.

24. How many degrees are the acute angles of a rhombus, if its side is the geometrical mean of the diagonals? (Definition: The geometrical mean of a and b is \sqrt{ab} .)

- A) 15° B) 30° C) 45° D) 60° E) 75°

25. In the diagram at the right we are shown a piece of the graph of the function $ax^3 + bx^2 + cx + d$. What is the value of b ?

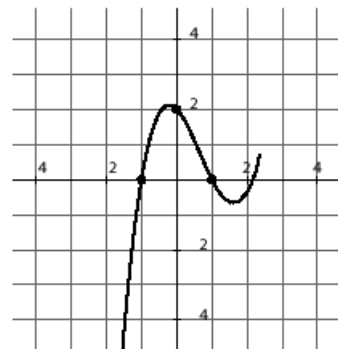

- A) -4 B) -2 C) 0 D) 2 E) 4

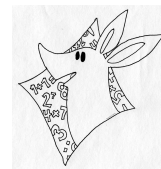

26. Determine the number of real numbers a such that the quadratic equation $x^2 + ax + 2007 = 0$ has two integer roots.

- A) 3 B) 4 C) 6 D) 8 E) another answer

27. The sum $\frac{1}{2\sqrt{1} + 1\sqrt{2}} + \frac{1}{3\sqrt{2} + 2\sqrt{3}} + \dots + \frac{1}{100\sqrt{99} + 99\sqrt{100}}$ is equal to

- A) $\frac{999}{1000}$ B) $\frac{99}{100}$ C) $\frac{9}{10}$ D) 9 E) 1

28. In a party five friends are going to give each other gifts in such a way that everybody gives one gift and receives one (of course, no one should receive his own gift). In how many ways is this possible?

- A) 5 B) 10 C) 44 D) 50 E) 120

29. The digits of the sequence 123451234512345 ... fill the cells on a sheet of paper in a spiral-like manner beginning from the marked cell (see the figure). Which digit is written in the cell placed 100 cells above the marked one?

	1	2	3	.	.
	5	2	3	4	5
	4	1	1	2	1
	3	5	4	3	2
	2	1	5	4	3

- A) 1 B) 2 C) 3 D) 4 E) 5

30. The increasing sequence 1, 3, 4, 9, 10, 12, 13, ... includes all the powers of 3 and all the numbers that can be written as the sum of different powers of 3. What is the 100th element of the sequence?

- A) 150 B) 981 C) 1234 D) 2401 E) 3^{100}